



THE BAKER'S
CROWN

MOC C300 SEEDING UNIT

By seeding your rolls, you can easily enhance your product range. With the compact MOC C300 seeding unit, we are able to support you with the decoration of your products. Easy in use and time-saving in cleaning.



MAIN FEATURES

- The seeding unit can be combined with various Koenig lines, such as the Artisan SFC dough sheeting machine or the Mini Rex Multi dough dividing and rounding machine
- Infeed height for horizontal infeed conveyor adjustable between 900 and 980 mm
- Transfer of the dough pieces through a height-adjustable infeed conveyor
- Moistening of the dough pieces with 2 water baths
- Water depth / immersion depth can be set separately for each water bath
- Height-adjustable transfer for turning the pieces, drop height approx. 130 mm, so that dough pieces with a length of approx. 150 mm can be turned
- Transfer directly into a rotating bowl with the respective spreading material
- Practical storage shelf underneath the unit
- Foldable tray shelf on the side
- Mesh belt easily removable for cleaning
- Entire seeding unit on mobile frame
- Unit is in stainless steel design

DETAILS



Water depth / immersion depth can be set separately for each water bath



Transfer directly into a rotating bowl with the respective spreading material



Mesh belt easily removable for cleaning

DIMENSIONS

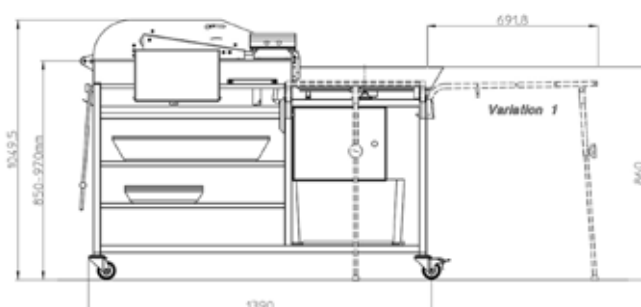

KÖNIG THE BAKER'S
CROWN

König Maschinen Gesellschaft m.b.H.
Stattegger Straße 80, 8045 Graz, AUSTRIA
Tel.: +43 316 6901-0, Fax: +43 316 6901-115
info@koenig-rex.com, www.koenig-rex.com